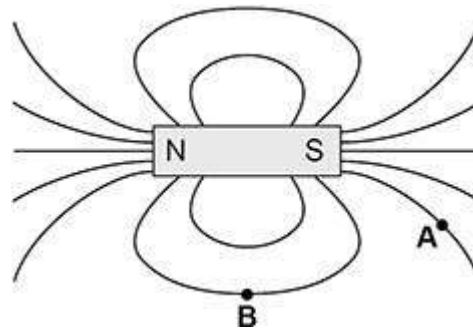

**1.****Figure 1** shows the magnetic field pattern around a bar magnet.**Figure 1**

- (a) Draw an arrow at point **A** and point **B** to show the direction of the magnetic field at each point.

(1)

- (b) A bar magnet produces its own magnetic field.

Complete the sentence.

Choose the answer from the box.

an electromagnet**an induced magnet****a permanent magnet**

A bar magnet is an example of _____.

(1)



(c) Which graph shows how the strength of the magnetic field varies with distance from the bar magnet?

Give a reason for your answer.

Tick (✓) **one** box.

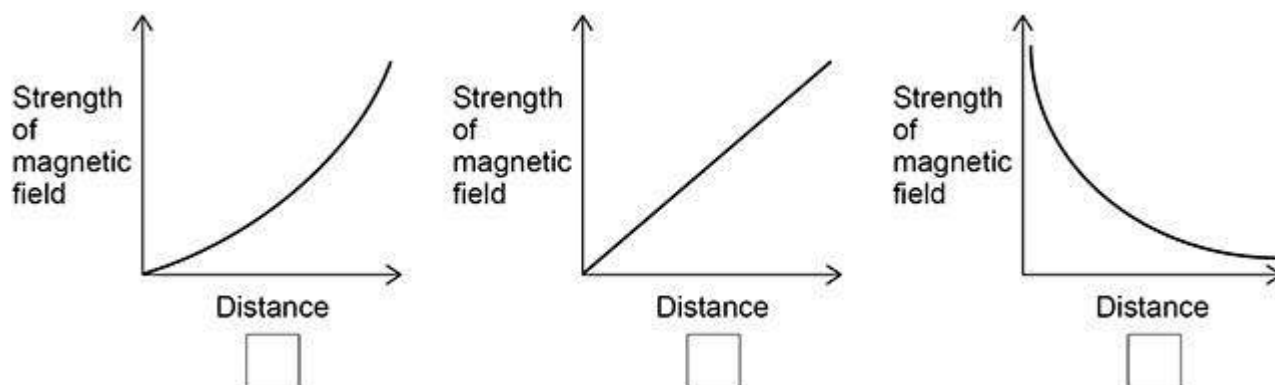

Reason _____

(2)

Figure 2 shows an electromagnet being used to separate aluminium cans from steel cans.

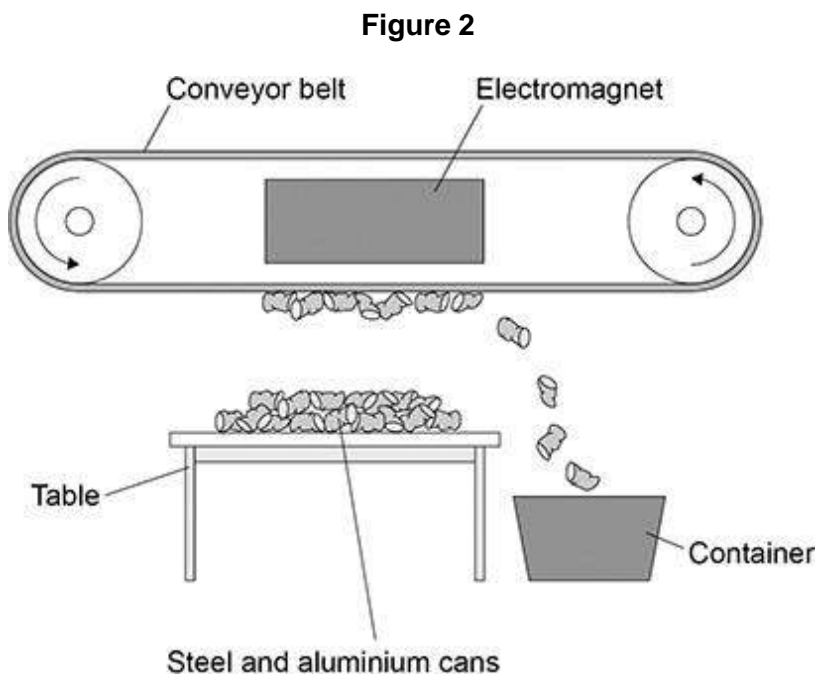



- (d) Explain how the electromagnet and conveyor belt are used to separate the steel cans from the aluminium cans.

(2)

- (e) At the top of the table the strength of the magnetic field is only just enough to pick the cans up.

Describe **two** ways to increase the strength of magnetic field at the top of the table.

1 _____

2 _____

(2)

- (f) Write down the equation which links distance travelled (s), speed (v) and time (t).

(1)

- (g) The conveyor belt moves a can at a speed of 1.7 m/s.

Calculate the time taken to move the can 3.3 m at this speed.

Give your answer to 2 significant figures.

Time taken (2 significant figures) = _____ s

(4)

(Total 13 marks)



2.

A student placed a magnet on top of a plastic support in a bowl of water. This magnet was fixed in position and above the surface of the water.

The student put a second magnet into a piece of cork so that the magnet floated on the water. Only the north pole of the floating magnet was above the surface of the water.

The photograph below shows the arrangement of the magnets.

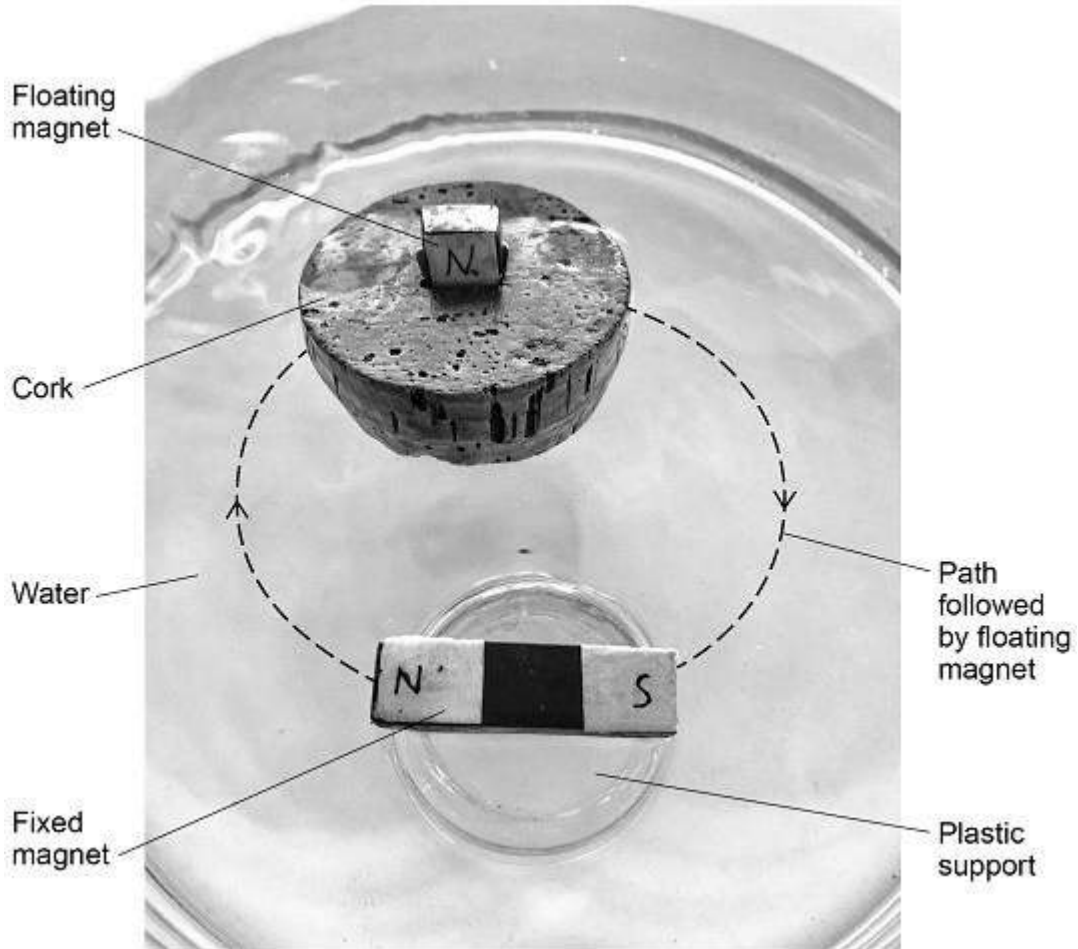

- (a) The floating magnet was placed near to the north pole of the fixed magnet. The floating magnet then moved along the path shown in the photograph.

Explain why.

(2)



- (b) The student replaced the floating magnet with a piece of iron.

What happened to the piece of iron?

(1)



(c) Describe how to use a compass to plot the magnetic field pattern around a bar magnet.

Use **Figure 1** to help you.

Figure 1

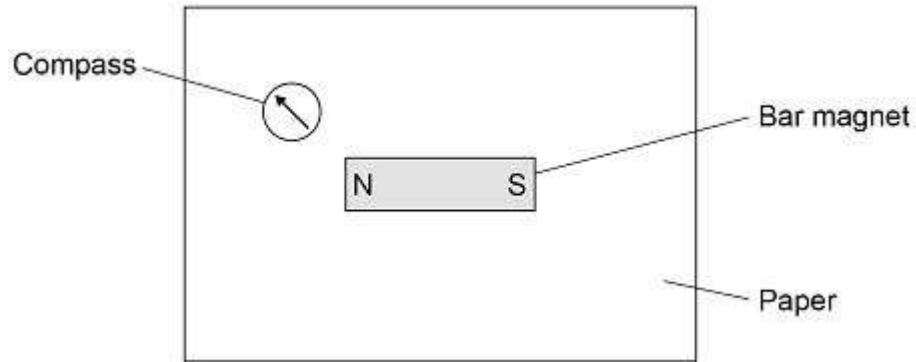

(4)

Figure 2 shows a diagram of an electromagnetic lock used to secure a door.

Figure 2

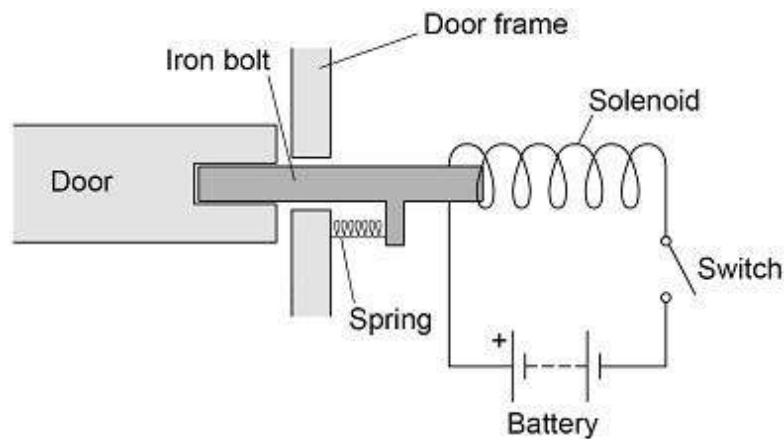



(d) **Figure 3** shows an incomplete sequence of how the door unlocks.

Figure 3



Write **one** letter in each box to show the correct sequence.

- A** The iron bolt moves.
- B** A magnetic field is created around the solenoid.
- C** There is a current in the circuit.

(2)

(e) The electromagnetic lock contains a spring.

When the door is unlocked the extension of the spring is 0.040 m.

spring constant = 200 N/m

Calculate the elastic potential energy of the spring when the door is unlocked.

Use the equation:

$$\text{elastic potential energy} = 0.5 \times \text{spring constant} \times (\text{extension})^2$$

Elastic potential energy = _____ J

(2)

(Total 11 marks)

3. (a) **Figure 1** shows a bar magnet.

Each circle represents a compass.

Figure 1



Draw an arrow inside each circle to show the direction that each compass would point.

(1)



(b) **Figure 2** shows part of a coat.

The coat has two magnets hidden inside the material.

Figure 3 shows how the magnets are used to fasten the coat.

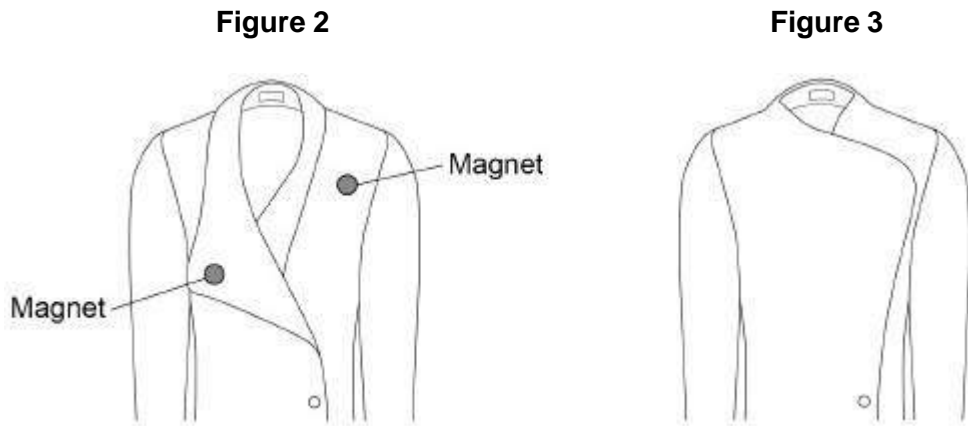

Explain why the magnets inside the coat must **not** have two south poles facing each other.

(2)

A coil of wire is connected to a battery.

The current in the coil produces a magnetic field.

(c) Which diagram in **Figure 4** shows the magnetic field produced by the current in the coil?

Tick (✓) **one** box.

Figure 4

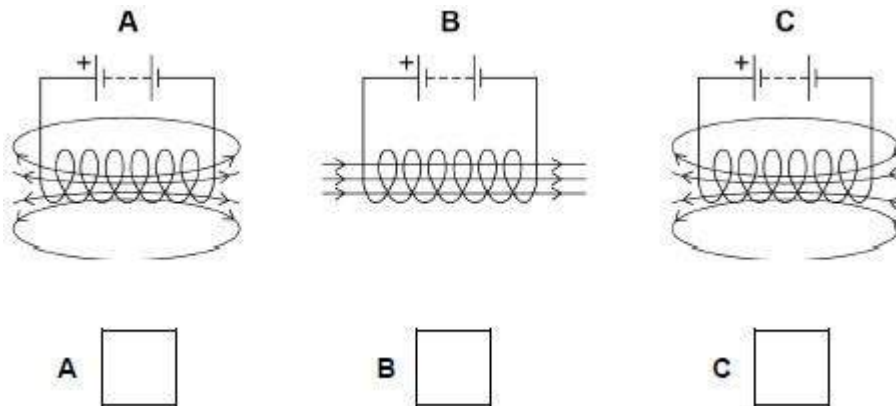

A

B

C

(1)



(d) A solid rod is placed inside the coil.

Which type of rod would make the magnetic field of the coil stronger?

Tick (✓) **one** box.

- Glass rod
- Plastic rod
- Steel rod
- Wooden rod

(1)

A student investigated how the strength of an electromagnet varies with the current in the coil of the electromagnet.

Figure 5 shows the equipment the student used.

Figure 5

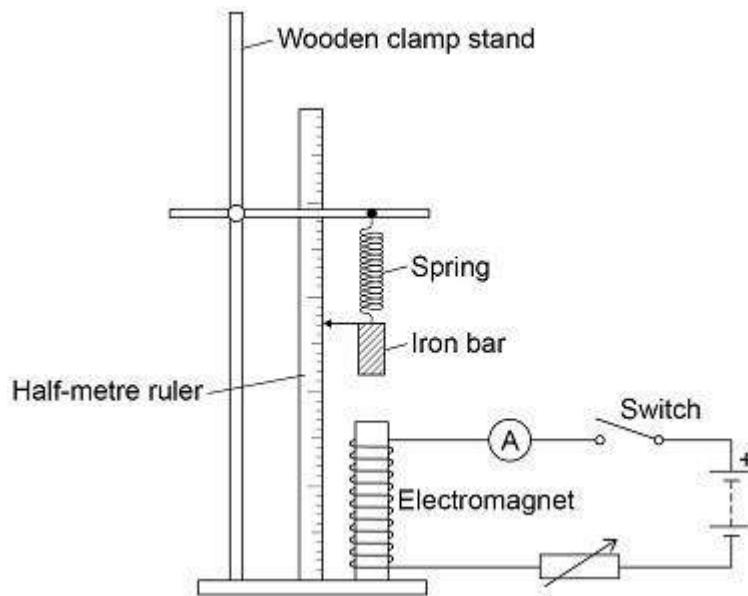

(e) Why does the spring get longer when the electromagnet is switched on?



The student measured how much further the spring extended with different values of current in the coil.

Figure 6 shows the results.

Figure 6

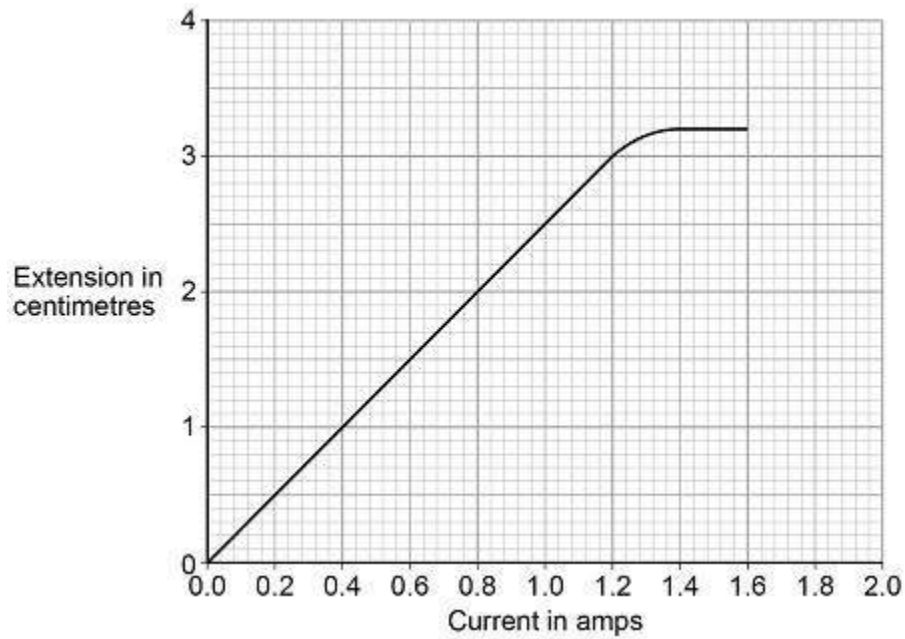

(f) The current in the coil is increased from 0.6 A to 1.2 A

Determine the increase in the extension of the spring.

Increase in the extension = _____ cm

(1)

(g) Calculate the increase in the force on the spring when the current in the coil increased from 0.6 A to 1.2 A

Spring constant = 0.18 N/cm

Use the equation:

$$\text{force} = \text{spring constant} \times \text{extension}$$

Increase in the force = _____ N

(2)



- (h) Describe what happened to the strength of the electromagnet as the current in the coil increased from 1.2 A to 1.6 A

(2)
(Total 11 marks)

4.

Figure 1 shows two paper clips hanging from a bar magnet.

Figure 1

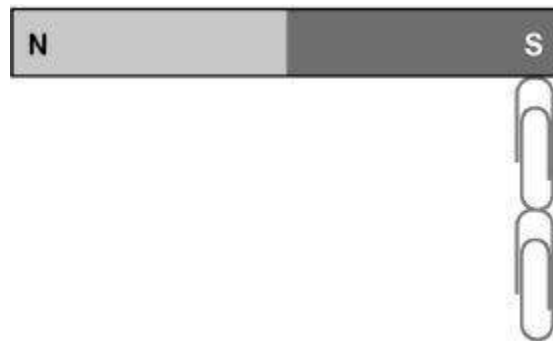

The paper clips have become magnetised.

- (a) Label the north and south poles of both paper clips.

(1)



A student investigated how the number of turns of wire on an electromagnet affects the strength of the electromagnet.

Figure 2 shows the equipment used by the student. Throughout the investigation the student kept the current through the wire constant.

Figure 2

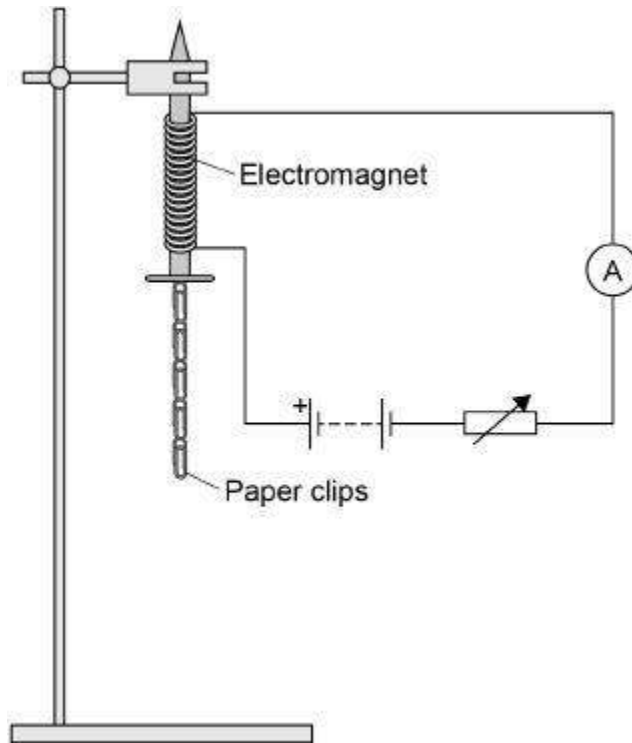

- (b) The student measured the strength of the electromagnet by counting the number of paper clips the electromagnet could hold.

Explain why it was important that the paper clips were all the same size.

(2)



The table below shows the student's results.

Number of turns of wire on the electromagnet	Number of paper clips held
10	3
20	6
30	9
40	12

- (c) Describe the pattern shown in the table.

(2)

- (d) The student then used 50 turns of wire on the electromagnet.

The electromagnet picked up 18 paper clips. This was more paper clips than the student had expected.

Which **one** is the most likely cause of this result?

Tick **one** box.

The paper clips used with 50 turns were larger than the others.

There were less than 50 turns of wire on the electromagnet.

Some of the paper clips were already magnetised.

(1)



- (e) The student repeated the measurement for 50 turns of wire three more times.

This gave her the following set of results.

18 16 14 15

Explain what the student should now do with the **four** results for 50 turns of wire.

(3)

- (f) The student wrote the hypothesis:

'Increasing the current through the wire will make the electromagnet stronger.'

Describe how the student should change the investigation to test this hypothesis.

(3)

(Total 12 marks)

5.

Figure 1 shows two bar magnets suspended close to each other.

Figure 1

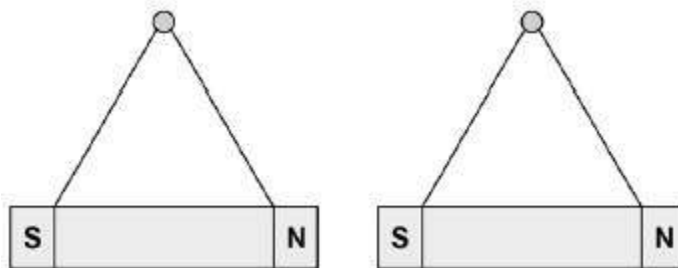



(a) Explain what is meant by the following statement.

'A non-contact force acts on each magnet'.

(2)

(b) Describe how to plot the magnetic field pattern of a bar magnet.

(3)

A student has set up the apparatus shown in **Figure 2**.

The iron rod is fixed to the track and cannot move.

Figure 2

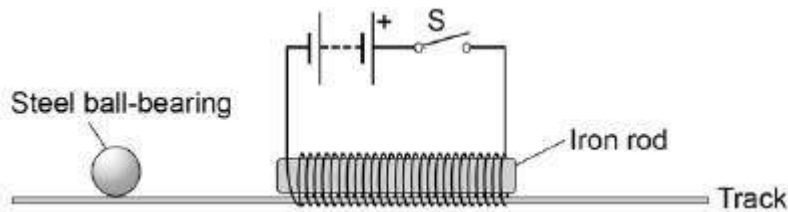



(c) The student gives the steel ball bearing a gentle push in the direction of the iron rod.

At the same time the student closes the switch **S**.

Explain the effect on the motion of the ball bearing when the switch **S** is closed.

(4)

(Total 9 marks)

6. **Figure 1** shows two iron nails hanging from a bar magnet.

The iron nails which were unmagnetised are now magnetised.

Figure 1

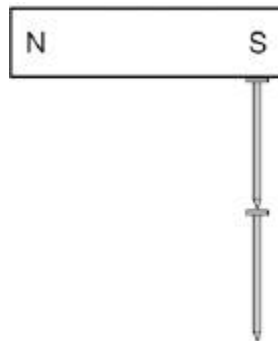

(a) Complete the sentence.

Use a word from the box.

forced	induced	permanent
---------------	----------------	------------------

The iron nails have become _____ magnets.

(1)



- (b) Each of the three metal bars in **Figure 2** is either a bar magnet or a piece of unmagnetised iron.

The forces that act between the bars when different ends are placed close together are shown by the arrows.

Figure 2

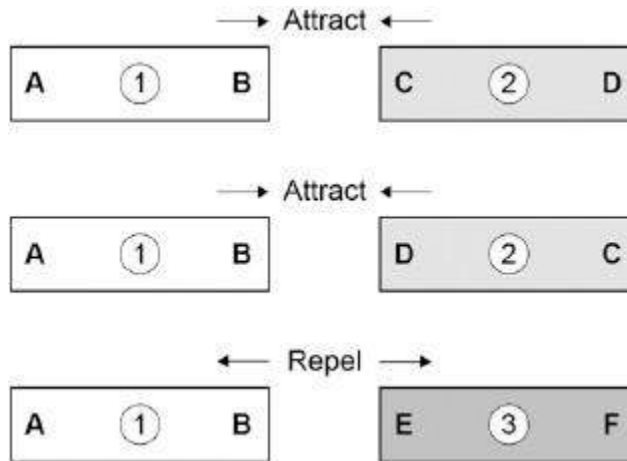

Which **one** of the metal bars is a piece of unmagnetised iron?

Tick **one** box.

Bar 1

Bar 2

Bar 3

Give the reason for your answer.

(2)



- (c) A student investigated the strength of different fridge magnets by putting small sheets of paper between each magnet and the fridge door.

The student measured the maximum number of sheets of paper that each magnet was able to hold in place.

Why was it important that each small sheet of paper had the same thickness?

(1)

- (d) Before starting the investigation the student wrote the following hypothesis:

'The bigger the area of a fridge magnet the stronger the magnet will be.'

The student's results are given in the table below.

Fridge magnet	Area of magnet in mm ²	Number of sheets of paper held
A	40	20
B	110	16
C	250	6
D	340	8
E	1350	4

Give **one** reason why the results from the investigation **do not** support the student's hypothesis.

(1)

(Total 5 marks)

**7.**

Figure 1 shows a straight wire passing through a piece of card.

A current (I) is passing down through the wire.

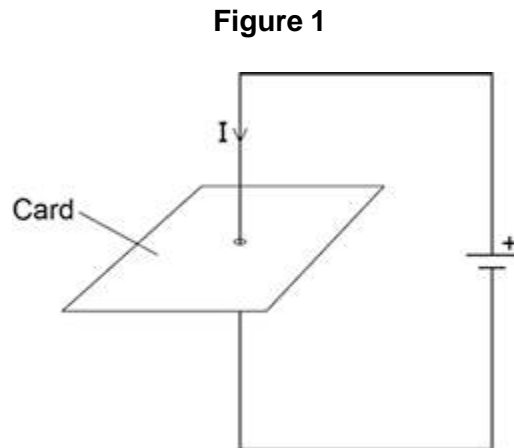

- (a) Describe how you could show that a magnetic field has been produced around the wire.

(2)



(b) **Figure 2** shows the ignition circuit used to switch the starter motor in a car on.

The circuit includes an electromagnetic switch.

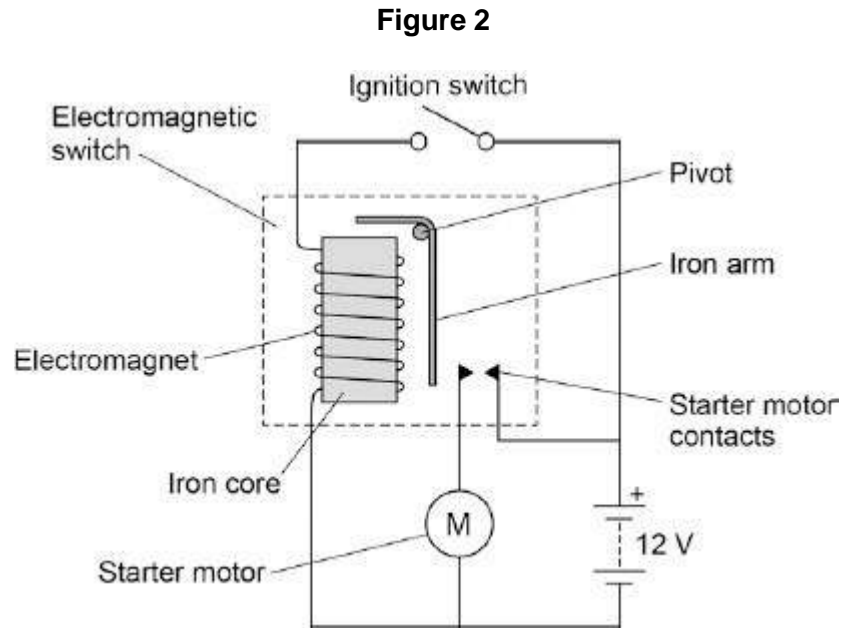

Explain how the ignition circuit works.

(4)
(Total 6 marks)